

# VRT SERIES Inline Planetary

## VRT 140 1-Stage Dimensions

Input bore size  $\leq \varnothing 28$  mm

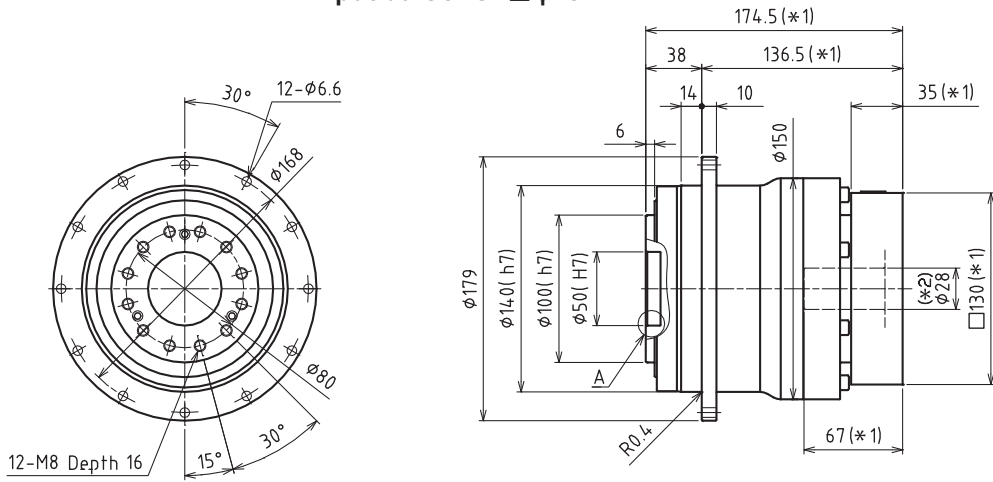

Input bore size  $\leq \varnothing 38$  mm

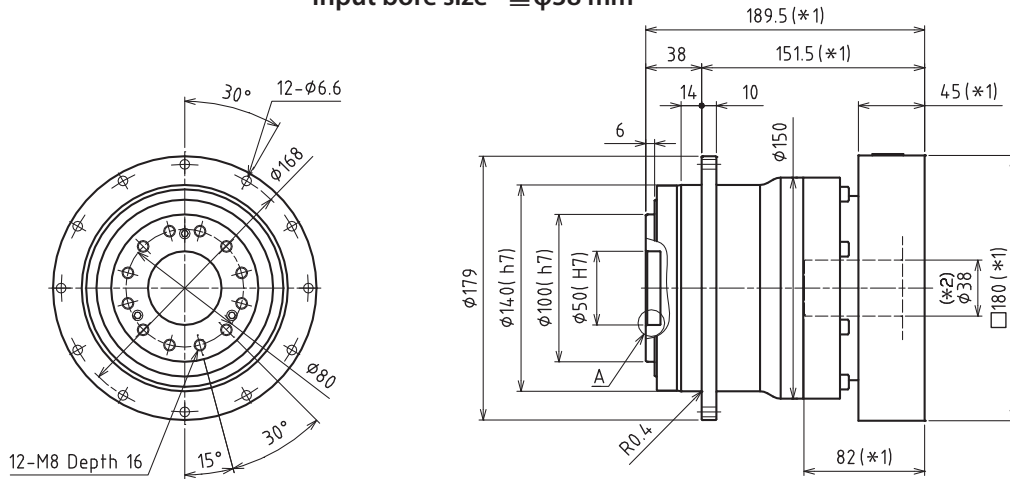

Input bore size  $\leq \varnothing 48$  mm

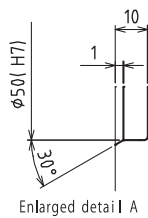
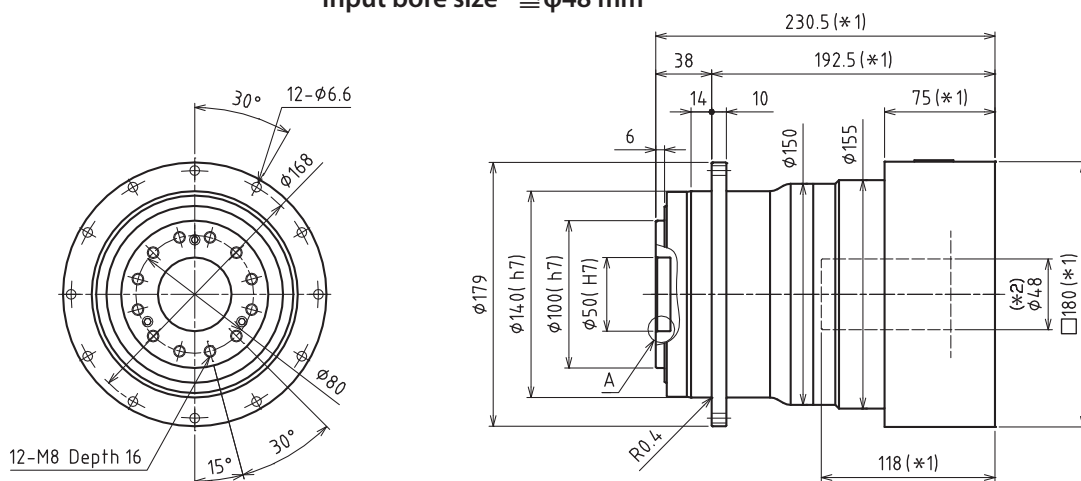

\*1) Length will vary depending on motor.

\*2) Bushing will be inserted to adapt to motor shaft

