

VRT SERIES Inline Planetary

VRT 110 1-Stage Dimensions

Input bore size $\leq \varnothing 19$ mm

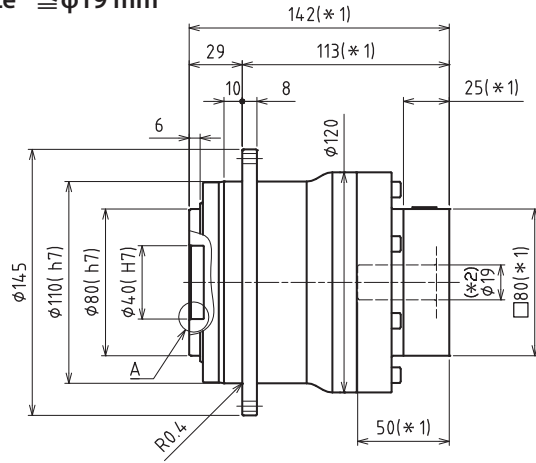
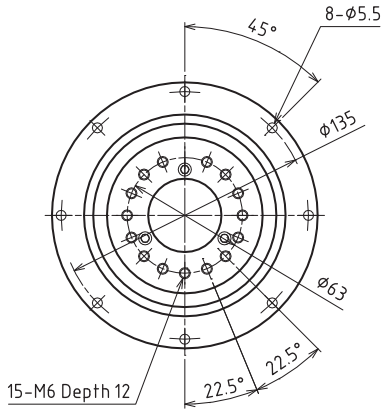

Input bore size $\leq \varnothing 28$ mm

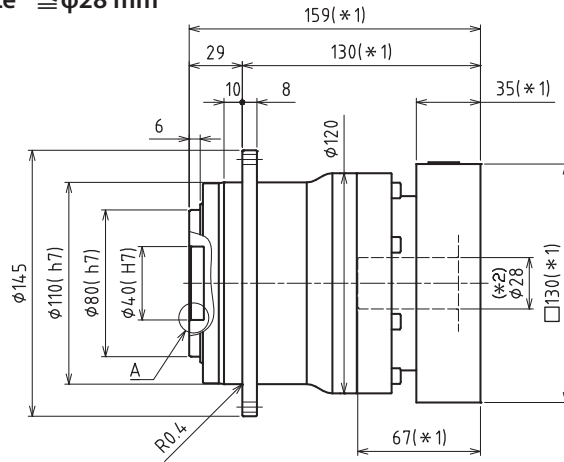
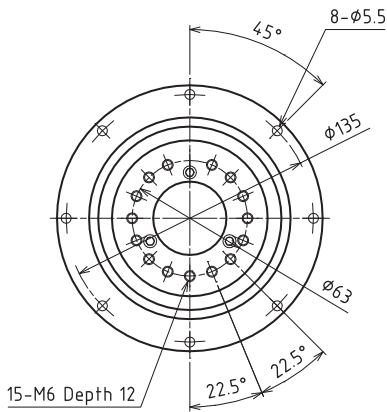

Input bore size $\leq \varnothing 38$ mm

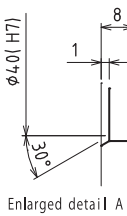
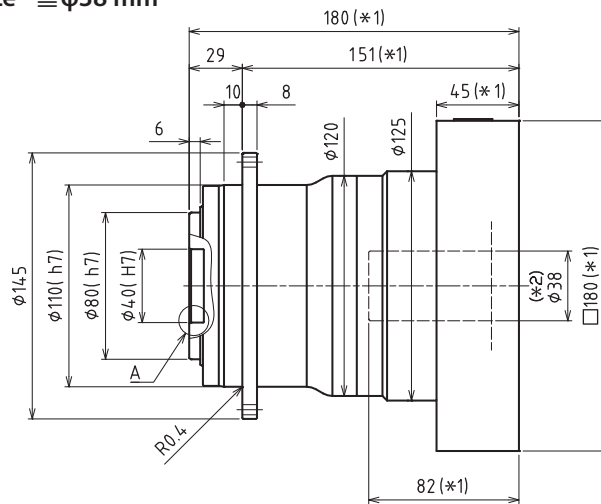
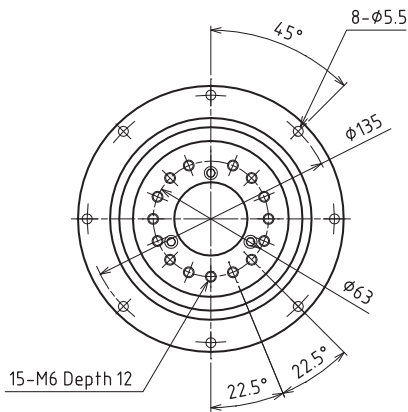

*1) Length will vary depending on motor

*2) Bushing will be inserted to adapt to motor shaft

VRT 110 2-Stage Dimensions

Input bore size $\geq \phi 14$ mm

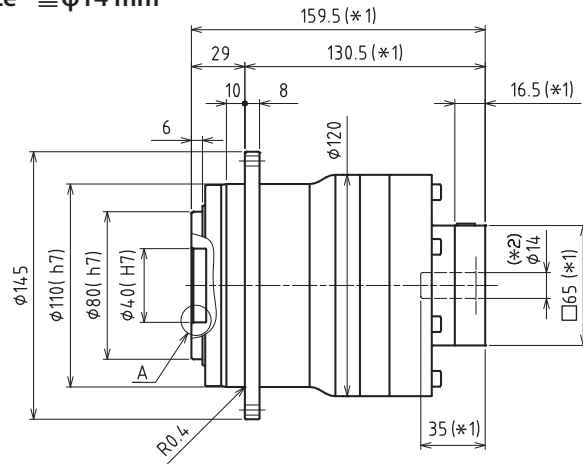
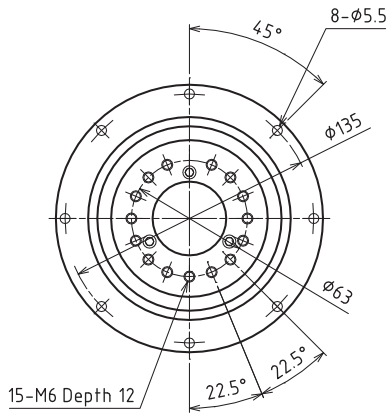

Input bore size $\geq \phi 19$ mm

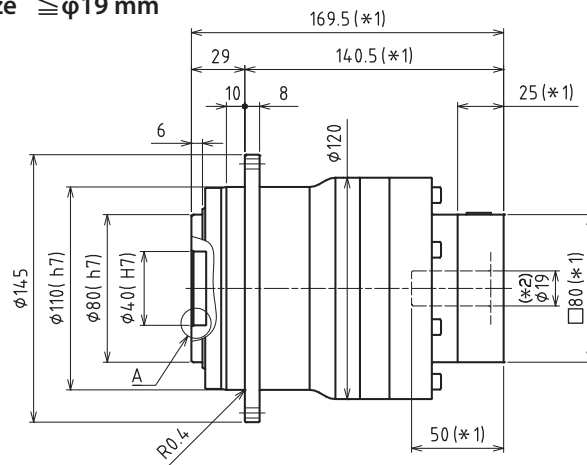
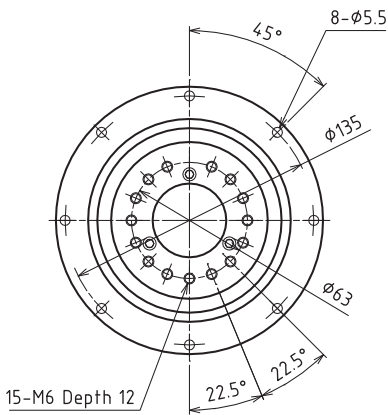

Input bore size $\geq \phi 28$ mm ^(*3)

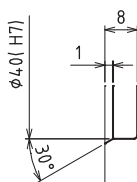
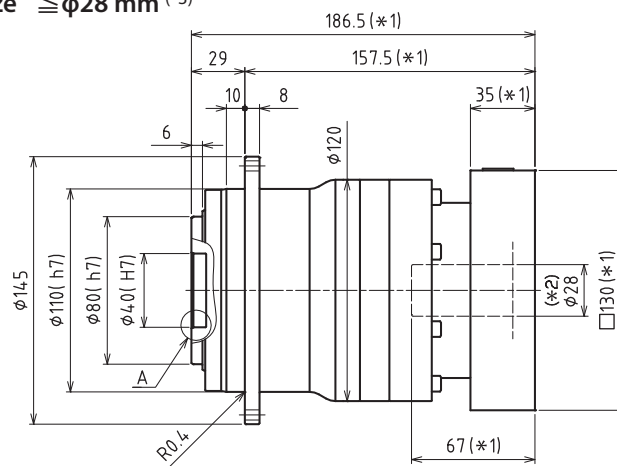
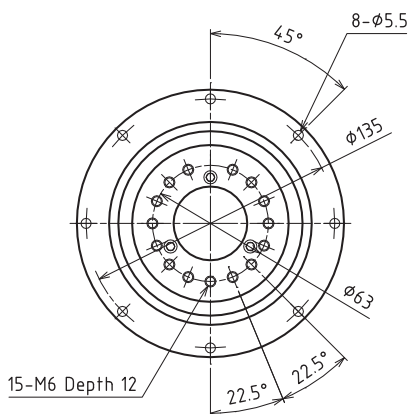

Enlarged detail A

*1) Length will vary depending on motor

*2) Bushing will be inserted to adapt to motor shaft

*3) 38mm input bore is available for this frame size. Use our online configurator to make your selection or contact us for assistance