

# Installation Instructions and Safety Precautions

## Inline and Right-angle Planetary Products - VR/EV Series

### Inspection and Preparations

- Upon delivery of the gearbox, confirm that you received the exact model that was specified on your purchase order.
- Inspect for shipping damage. Notify the shipping agent immediately if any damage is discovered.
- Remove the protective covering from the output shaft.

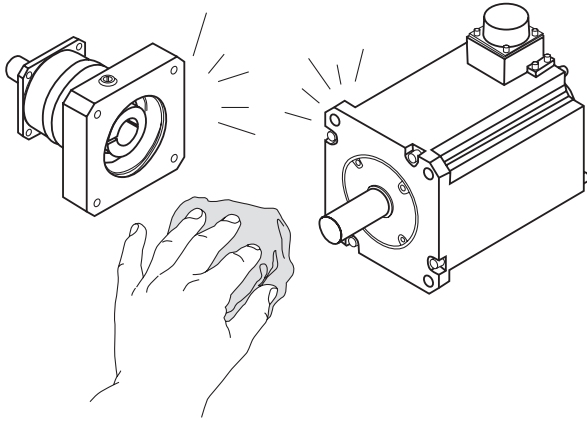

- Clean and de-grease the motor mounting surface and shaft, as well as the gearbox mounting surface, input hub bore, and shaft bushing (if included). This cleaning is very important for the shaft and bushing, to prevent slip during motion.

### Motor Mounting

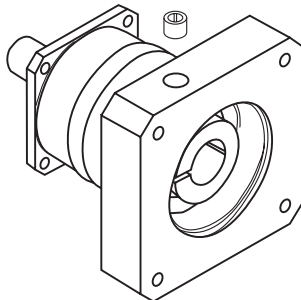

- Remove the access hole plug, allowing access to the motor shaft clamp.

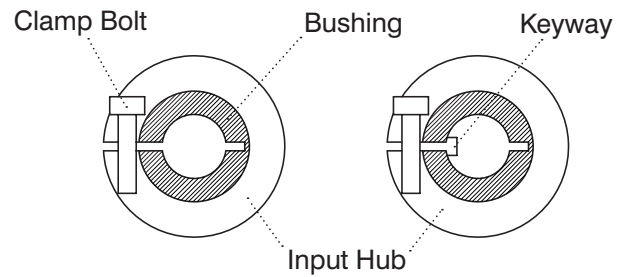

- Carefully align the shaft bushing (if included) so that the opening in the bushing aligns with the opening in the input hub. It is also recommended that the motor shaft keyway (if present) aligns with the opening in the input hub clamp.

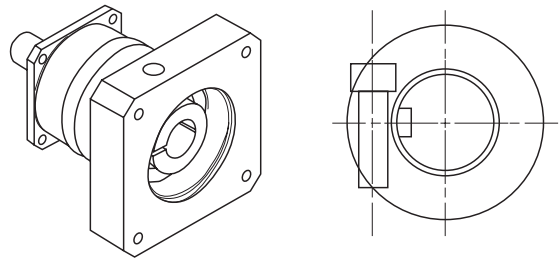

- Rotate the gearbox input hub so that the clamp bolt is aligned with the access hole. Loosen the clamp bolt.
- Remove the motor key (if supplied), as it is not required for proper installation and operation.

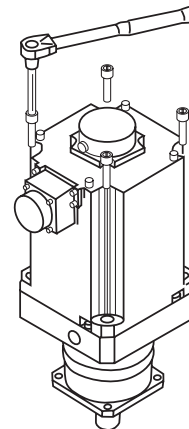

- Slowly slide the motor into the gearbox, so that the motor shaft enters the gearbox input hub with motor shaft keyway (if present) aligned with gearbox input shaft clamp opening. Install the four motor flange bolts in a cross-wise pattern, to ensure proper alignment of motor to gearbox. Tighten the bolts to the proper torque using a torque wrench (see Table A).

**Nidec**

**NIDEC-SHIMPO AMERICA CORPORATION**

175 Wall Street, Glendale Heights, IL 60139, USA • P: (800) 842-1479 • [www.drives.nidec-shimpo.com](http://www.drives.nidec-shimpo.com) • [drives@nidec-shimpo.com](mailto:drives@nidec-shimpo.com)

**Table A**

Motor Installation Bolt Size	Tightening Torque	
	(Nm)	(in lbs)
M3	1.1	9.7
M4	2.5	22.1
M5	5.1	45.1
M6	8.7	77
M8	21	186
M10	42	372
M12	72	637

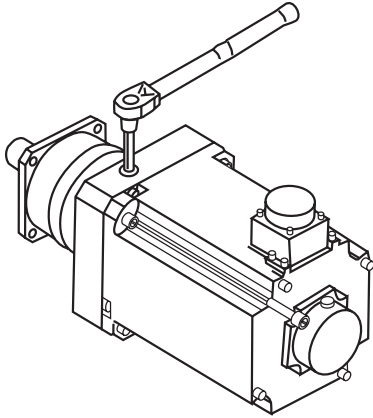

- F. Tighten the gearbox input shaft clamp bolt to the proper torque using a torque wrench (see Table B).

**Table B**

Clamp Bolt Size	Tightening Torque	
	(Nm)	(in lbs)
M3	1.9	16.8
M4	4.3	38.1
M5	8.7	77
M6	15	133
M8	36	318
M10	71	628
M12	125	1106

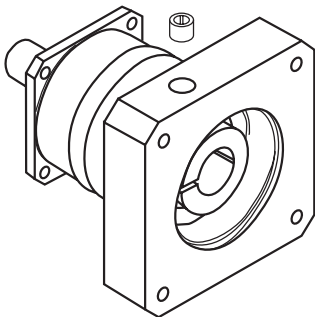

- G. Re-install the access hole plug into the motor adapter plate. Assembly is complete.

## Safety Precautions

- A. Avoid use in wet or corrosive areas, unless the gearbox is specified for these environments.
- B. Ambient temperature in the area of the gearbox must be in the range of 0° -40°C, unless the gearbox is built to withstand a different temperature range.
- C. The gearbox (with motor) must be firmly attached to a vibration-free frame or fixture.
- D. The gearbox has been lubricated and can be operated immediately.
- E. At initial operation, check the direction of shaft rotation, then apply the load gradually.
- F. Avoid excessive loads.
- G. Ensure that the motor speed does not exceed the maximum RPM specified for the gearbox.
- H. Watch for the following problems and discontinue motion immediately:
  - a. Sharp increase in temperature
  - b. Abnormal noise
  - c. Unstable output speed
- I. The gearbox is not designed to be disassembled.
- J. The gearbox is lubricated for its lifetime with appropriate grease. No re-lubrication is required.

## IP 65 Versions

If you have received an IP65 version of the gearbox, be sure to seal between the gearbox and motor interface with a sealant to ensure an IP65 rating of the gearbox / motor assembly. Also apply sealant to the access hole plug during step "G". Please contact NIDEC-SHMPO with any questions.

# Nidec

**NIDEC-SHMPO AMERICA CORPORATION**

175 Wall Street, Glendale Heights, IL 60139, USA • P: (800) 842-1479 • www.drives.nidec-shimpo.com • drives@nidec-shimpo.com