

# Motor Mounting Codes

## Motor Mounting Codes

Our motor mounting codes can be configured automatically using our online selection tool. These tables supply the details behind these codes. The tables start with Input Bore measurement and the Part # Code, which are indicated at the end of every model code. For each Part # Code, the Pilot, BCD, Tapped Hole, and Pilot Depth, are explained.

Please note that even though the Part# Code may have the same letters (i.e. DC, FB, HA, etc), the Pilot and BCD dimensions may not be the same if a different input bore diameter. Locate the table by input bore diameter first, and then find the appropriate adapter Part# Code to check the dimensions. If you have any questions, contact NIDEC-SHIMPO for support.

Input Bore (mm)	Part# Code	Pilot (mm)	BCD (mm)	Tapped Hole	Pilot Depth (mm)
65	MA	114.3	200	M12	8
65	MB	200	235	M12	8
65	MC	180	215	M12	8
65	MD	180	265	M12	8
65	NA	230	265	M12	8
65	NB	230	265	M12	18
65	NC	230	290	M12	8
65	ND	230	265	M20	18
65	PA	250	300	M16	8
65	PB	250	320	M16	18
65	QA	300	350	M16	8
65	QB	280	325	M16	8

Input Bore (mm)	Part# Code	Pilot (mm)	BCD (mm)	Tapped Hole	Pilot Depth (mm)
48	KA	114.3	200	M12	8
48	KB	110	130	8.8	8
48	KC	130	215	M12	8
48	LA	180	215	M12	8
48	MA	180	265	M12	8
48	MB	200	235	M12	8
48	NA	230	265	M12	8
48	PA	250	300	M16	8

Input Bore (mm)	Part# Code	Pilot (mm)	BCD (mm)	Tapped Hole	Pilot Depth (mm)
38	HA	110	130	8.8	8
38	HB	110	145	M8	8
38	HE	110	130	M8	8
38	JA	130	165	M10	8
38	KA	114.3	200	M12	8
38	KB	130	215	M10	8
38	KC	130	215	M12	8
38	KD	95	200	M10	18
38	KE	114.3	200	M12	18
38	LA	180	215	M12	8
38	LB	180	215	M12	18
38	MA	180	265	M12	8
38	MB	200	235	M12	8
38	MC	215.9	184.15	13.7	5.5
38	MD	200	250	M8	18
38	NA	230	265	M12	8

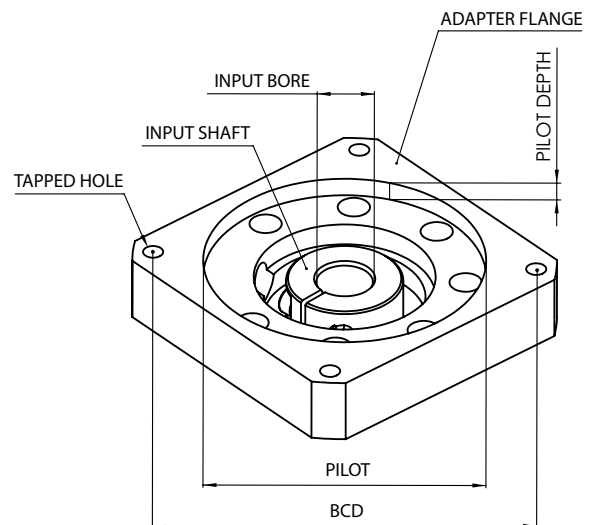

## Motor Mounting Codes

Input Bore (mm)	Part# Code	Pilot (mm)	BCD (mm)	Tapped Hole	Pilot Depth (mm)
28	FA	80	100	M6	8
28	FB	95	115	M6	8
28	FC	95	115	M8	8
28	FD	95	115	M6	8
28	FE	95	115	M8	8
28	GA	55.563	125.73	M6	8
28	GB	63.5	127	M6	8
28	GC	95	130	M8	8
28	GD	110	130	M8	8
28	GE	110	130	M10	8
28	GF	110	130	8.8	8
28	GG	110	135	M8	8
28	GH	95	135	M8	8
28	HA	110	145	M8	8
28	HB	110	145	M8	18
28	HC	110	145	10.5	8
28	HD	114.3	149.23	10.5	8
28	HE	95	145	M8	18
28	HF	110	145	M8	8
28	JA	110	165	M8	8
28	JB	110	165	M10	8
28	JC	130	165	M10	8
28	JD	130	174	M10	28
28	JE	130	165	M10	18
28	JF	114.3	160	M10	8
28	KA	114.3	200	M12	8
28	KB	130	215	M10	8
28	KD	114.3	200	M12	18
28	KE	150	185	M10	8
28	LA	180	215	M12	8
28	LB	180	220	M12	18
28	MA	200	235	M12	8
28	MB	200	250	M8	18

Input Bore (mm)	Part# Code	Pilot (mm)	BCD (mm)	Tapped Hole	Pilot Depth (mm)
19	DA	60	90	M5	6
19	DB	70	90	M5	6
19	DC	70	90	M6	6
19	DD	70	90	M6	16
19	DE	70	90	M5	11
19	EA	73.025	98.43	M5	11
19	EB	80	100	M6	6
19	EC	80	100	M6	16
19	ED	60	98.99	M6	6
19	FA	95	115	M8	6
19	FB	95	115	M8	16
19	GA	55.563	125.73	M6	11
19	GB	95	130	M8	6
19	GC	110	130	M8	11
19	GD	110	130	8.8	6
19	GE	95	130	M8	16
19	GF	100	125	M8	16
19	GH	95	135	M8	11
19	HA	110	145	M8	6
19	HB	110	145	M8	21
19	HC	110	145	10.5	11
19	HD	114.3	149.23	M8	11
19	HE	114.3	149.23	10.5	11
19	JA	130	165	M10	16
19	JB	115	165	M8	21

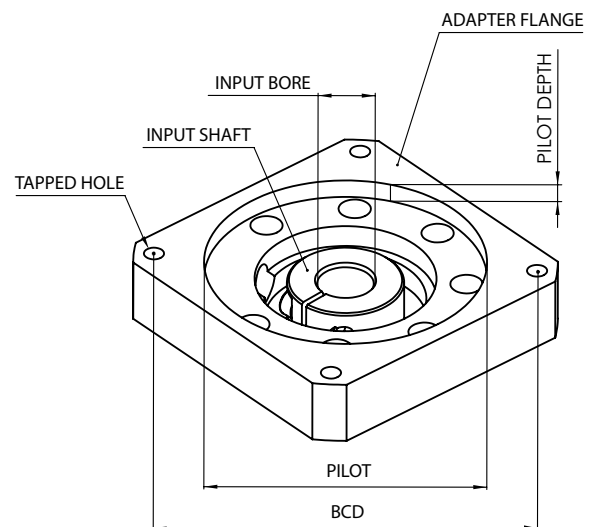

# Motor Mounting Codes

## Motor Mounting Codes

Our motor mounting codes can be configured automatically using our online selection tool. These tables supply the details behind these codes. The tables start with Input Bore measurement and the Part # Code, which are indicated at the end of every model code. For each Part # Code, the Pilot, BCD, Tapped Hole, and Pilot Depth, are explained.

Please note that even though the Part# Code may have the same letters (i.e. DC, FB, HA, etc), the Pilot and BCD dimensions may not be the same if a different input bore diameter. Locate the table by input bore diameter first, and then find the appropriate adapter Part# Code to check the dimensions. If you have any questions, contact NIDEC-SHIMPO for support.

Input Bore (mm)	Part# Code	Pilot (mm)	BCD (mm)	Tapped Hole	Pilot Depth (mm)
14	BA	38.1	66.68	M4	5
14	BB	38.1	66.68	M5	5
14	BC	38.1	66.68	M5	10
14	BD	40	63	M4	5
14	BE	40	63	M5	5
14	BF	40	65	M5	5
14	BG	40	70	M4	5
14	BH	50	60	M4	10
14	BJ	50	70	M4	5
14	BK	50	70	M5	5
14	BL	50	70	M5	15
14	BM	50	70	M5	10
14	BN	50	70	M4	10
14	BP	36	70.71	M4	5
14	CA	60	75	M5	5
14	CB	60	75	M6	10
14	CC	60	80	M4	5
14	DA	50	95	M6	5
14	DB	60	85	M5	5
14	DC	60	90	M5	5
14	DD	70	85	6.5	5
14	DE	70	90	M5	10
14	DF	70	90	M6	5

Input Bore (mm)	Part# Code	Pilot (mm)	BCD (mm)	Tapped Hole	Pilot Depth (mm)
14	DG	70	90	M6	15
14	DH	70	95	M6	5
14	DJ	60	95	M5	5
14	DK	36.8	82.024	M6	15
14	DL	62	91.924	M5	10
14	EA	50	100	M6	5
14	EB	73.025	98.43	M5	5
14	EC	80	100	M6	5
14	ED	80	100	M6	15
14	EE	73.025	98.43	M6	15
14	EF	50	98.43	M5	5
14	EG	60	98.995	M5	5
14	EH	80	105	M6	15
14	EJ	60	98.995	M6	10
14	EK	73.025	98.43	M6	5
14	EL	73	94	M6	5
14	EM	83	104	M8	10
14	FA	60	115	M6	5
14	FB	95	115	M8	15
14	GA	80	139.7	M6	5
14	GB	80	130	M5	20
14	GC	94	120	M8	10
14	JA	115	165	M8	10

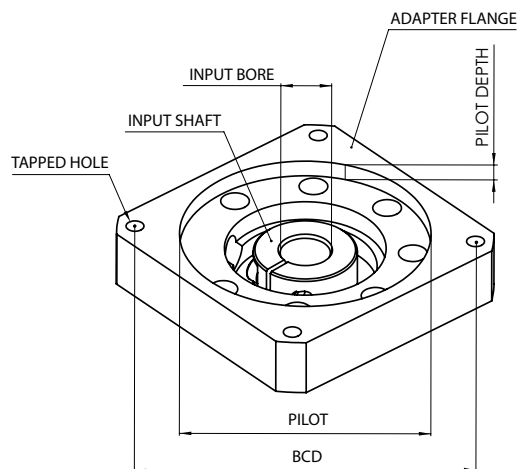

## Motor Mounting Codes

Input Bore (mm)	Part# Code	Pilot (mm)	BCD (mm)	Tapped Hole	Pilot Depth (mm)
8	AA	20.02	46.69	M3	5
8	AB	22	43.82	4.7	10
8	AC	22	48	M3	5
8	AD	22.22	50.8	M3	5
8	AE	25.4	38.89	4	10
8	AF	30	45	M3	5
8	AG	30	46	M4	5
8	AH	30	46	M4	10
8	AJ	30	46	3.5	10
8	AK	34	48	M3	10
8	AL	30	48	M3	5
8	AM	22	43.82	3.5	5
8	AN	40	50	M4	5
8	AQ	37.6	48	M3	5
8	BA	38.1	66.68	M4	5
8	BB	38.1	66.68	M5	5
8	BC	50	60	M4	10
8	BD	50	70	M4	5
8	BE	50	70	M5	5
8	BF	50	70	M5	10
8	BG	36	70.71	M4	5
8	BH	54	70	M4	5
8	BJ	50	58	M3	5
8	CA	50	80	M4	10

Input Bore (mm)	Part# Code	Pilot (mm)	BCD (mm)	Tapped Hole	Pilot Depth (mm)
S8	ZA	20.02	46.69	M3	5
S8	ZB	22	43.82	4.7	10
S8	ZC	22	48	M3	5
S8	ZD	22.22	50.8	M3	5
S8	ZE	25.4	38.89	4	10
S8	ZF	30	45	M3	5
S8	ZG	30	46	M4	5
S8	ZH	30	46	M4	10
S8	ZJ	30	46	3.5	10
S8	ZK	34	48	M3	10
S8	ZL	30	48	M3	5
S8	ZM	22	43.82	3.5	5
S8	ZN	40	50	M4	5
S8	ZQ	37.6	48	M3	5
S8	BA	38.1	66.68	M4	5
S8	BB	38.1	66.68	M5	5
S8	BC	50	60	M4	10
S8	BD	50	70	M4	5
S8	BE	50	70	M5	5
S8	BF	50	70	M5	10
S8	BG	36	70.71	M4	5
S8	BH	54	70	M4	5
S8	BJ	50	58	M3	5

