

# STR SERIES Hollow Rotary Index Tables

## STR 160V 1-Stage and 2-Stage Specifications with VRB 115

Frame Size	160V									
Stage			1-Stage	2-Stage						
Ratio	Units	Notes	20	60	80	100	120	140	160	180
Nominal Torque	[Nm]	*1	1165	1165	1165	1165	1165	1165	1165	1165
Acceleration Torque	[Nm]	--	1888	1888	1888	1888	1888	1888	1888	1888
No Load Torque	[Nm]	*1	6.6	1.1	1.1	1.1	1.1	1.1	1.1	1.1
Nominal Input Speed	[rpm]	*2	500	1500	2000	2500	3000	3000	3000	3000
Maximum Input Speed	[rpm]	*2	1000	3000	4000	5000	6000	6000	6000	6000
Reflected Inertia (Single)	[kg-m <sup>2</sup> x10 <sup>-4</sup> ]	*3	46.99	--	--	--	--	--	--	--
Reflected Inertia (≤Ø 14)	[kg-m <sup>2</sup> x10 <sup>-4</sup> ]	*3	--	--	--	--	--	--	--	--
Reflected Inertia (≤Ø 19)	[kg-m <sup>2</sup> x10 <sup>-4</sup> ]	*3	--	3.417	2.117	1.717	1.417	1.217	1.117	1.097
Reflected Inertia (≤Ø 28)	[kg-m <sup>2</sup> x10 <sup>-4</sup> ]	*3	--	5.417	4.217	3.717	3.417	3.317	3.217	3.117
Reflected Inertia (≤Ø 38)	[kg-m <sup>2</sup> x10 <sup>-4</sup> ]	*3	--	13.12	12.12	11.12	11.12	11.12	11.12	11.12
Backlash	[arc-min]	--	0	0	0	0	0	0	0	0
Angular Transmission Accuracy	[arc-min]	--	≤ 1.5	≤ 1.5						
Angular Repeatability Accuracy	[arc-min]	--	± 0.15	± 0.15						
Surface Runout	[µm (max)]	--	20	20	20	20	20	20	20	20
Weight	[kg]	--	126	134	134	134	134	134	134	134
Maximum Axial Load	[N]	--	17170	17170	17170	17170	17170	17170	17170	17170
Maximum Radial Load	[N]	--	7283	7283	7283	7283	7283	7283	7283	7283
Maximum Tilting Moment Load	[Nm]	--	1216.3	1216.3	1216.3	1216.3	1216.3	1216.3	1216.3	1216.3
Efficiency	[%]	--	80	76	76	76	76	76	76	76
Protection Class	--	*4	IP54 (IP65)							

\*1) At nominal input speed

\*2) Speeds are at the actuator input. Limits when used with additional gearbox are higher

\*3) At input shaft

\*4) IP65 (wash-down) is available as an option. Contact NIDEC-SHIMPO for more details and our food grade options

## STR 160V 2-Stage and 3-Stage Specifications with VRB 115

Frame Size	160V									
Stage			2-Stage	3-Stage						
Ratio	Units	Notes	200	300	320	400	500	560	600	700
Nominal Torque	[Nm]	*1	1165	1165	1165	1165	1165	1165	1165	1165
Acceleration Torque	[Nm]	--	1888	1888	1888	1888	1888	1888	1888	1888
No Load Torque	[Nm]	*1	1.1	0.5	0.5	0.5	0.5	0.5	0.5	0.5
Nominal Input Speed	[rpm]	*2	3000	3000	3000	3000	3000	3000	3000	3000
Maximum Input Speed	[rpm]	*2	6000	6000	6000	6000	6000	6000	6000	6000
Reflected Inertia (Single)	[kg-m <sup>2</sup> x10 <sup>-4</sup> ]	*3	--	--	--	--	--	--	--	--
Reflected Inertia (≤Ø 14)	[kg-m <sup>2</sup> x10 <sup>-4</sup> ]	*3	--	0.547	0.597	0.517	0.497	0.557	0.407	0.487
Reflected Inertia (≤Ø 19)	[kg-m <sup>2</sup> x10 <sup>-4</sup> ]	*3	1.097	0.977	1.037	0.947	0.937	0.997	0.857	0.927
Reflected Inertia (≤Ø 28)	[kg-m <sup>2</sup> x10 <sup>-4</sup> ]	*3	3.117	2.917	3.017	2.917	2.917	2.917	2.817	2.817
Reflected Inertia (≤Ø 38)	[kg-m <sup>2</sup> x10 <sup>-4</sup> ]	*3	11.12	11.12	11.12	11.12	11.12	11.12	10.12	11.12
Backlash	[arc-min]	--	0	0	0	0	0	0	0	0
Angular Transmission Accuracy	[arc-min]	--	≤ 1.5	≤ 1.5						
Angular Repeatability Accuracy	[arc-min]	--	± 0.15	± 0.15						
Surface Runout	[µm (max)]	--	20	20	20	20	20	20	20	20
Weight	[kg]	--	134	135	135	135	135	135	135	135
Maximum Axial Load	[N]	--	17170	17170	17170	17170	17170	17170	17170	17170
Maximum Radial Load	[N]	--	7283	7283	7283	7283	7283	7283	7283	7283
Maximum Tilting Moment Load	[Nm]	--	1216.3	1216.3	1216.3	1216.3	1216.3	1216.3	1216.3	1216.3
Efficiency	[%]	--	76	72	72	72	72	72	72	72
Protection Class	--	*4	IP54 (IP65)							

\*1) At nominal input speed

\*2) Speeds are at the actuator input. Limits when used with additional gearbox are higher

\*3) At input shaft

\*4) IP65 (wash-down) is available as an option. Contact NIDEC-SHIMPO for more details and our food grade options

## STR 160V 3-Stage Specifications with VRB 115

Frame Size	160V									
Stage	3-Stage									
Ratio	Units	Notes	800	900	1000	1200	1400	1600	1800	2000
Nominal Torque	[Nm]	*1	1165	1165	1165	1165	1165	1165	1165	1165
Acceleration Torque	[Nm]	--	1888	1888	1888	1888	1888	1888	1888	1888
No Load Torque	[Nm]	*1	0.5	0.5	0.5	0.5	0.5	0.5	0.5	0.5
Nominal Input Speed	[rpm]	*2	3000	3000	3000	3000	3000	3000	3000	3000
Maximum Input Speed	[rpm]	*2	6000	6000	6000	6000	6000	6000	6000	6000
Reflected Inertia (Single)	[kg-m <sup>2</sup> ×10 <sup>-4</sup> ]	*3	--	--	--	--	--	--	--	--
Reflected Inertia (≤Ø 14)	[kg-m <sup>2</sup> ×10 <sup>-4</sup> ]	*3	0.397	0.487	0.397	0.397	0.397	0.397	0.387	0.387
Reflected Inertia (≤Ø 19)	[kg-m <sup>2</sup> ×10 <sup>-4</sup> ]	*3	0.847	0.917	0.847	0.847	0.847	0.847	0.847	0.847
Reflected Inertia (≤Ø 28)	[kg-m <sup>2</sup> ×10 <sup>-4</sup> ]	*3	2.817	2.817	2.817	2.817	2.817	2.817	2.817	2.817
Reflected Inertia (≤Ø 38)	[kg-m <sup>2</sup> ×10 <sup>-4</sup> ]	*3	10.12	11.12	10.12	10.12	10.12	10.12	10.12	10.12
Backlash	[arc-min]	--	0	0	0	0	0	0	0	0
Angular Transmission Accuracy	[arc-min]	--	≤ 1.5							
Angular Repeatability Accuracy	[arc-min]	--	± 0.15							
Surface Runout	[µm (max)]	--	20	20	20	20	20	20	20	20
Weight	[kg]	--	135	135	135	135	135	135	135	135
Maximum Axial Load	[N]	--	17170	17170	17170	17170	17170	17170	17170	17170
Maximum Radial Load	[N]	--	7283	7283	7283	7283	7283	7283	7283	7283
Maximum Tilting Moment Load	[Nm]	--	1216.3	1216.3	1216.3	1216.3	1216.3	1216.3	1216.3	1216.3
Efficiency	[%]	--	72	72	72	72	72	72	72	72
Protection Class	--	*4	IP54 (IP65)							

\*1) At nominal input speed

\*2) Speeds are at the actuator input. Limits when used with additional gearbox are higher

\*3) At input shaft

\*4) IP65 (wash-down) is available as an option. Contact NIDEC-SHIMPO for more details and our food grade options

## STR 160 Dimensions with VRB 115

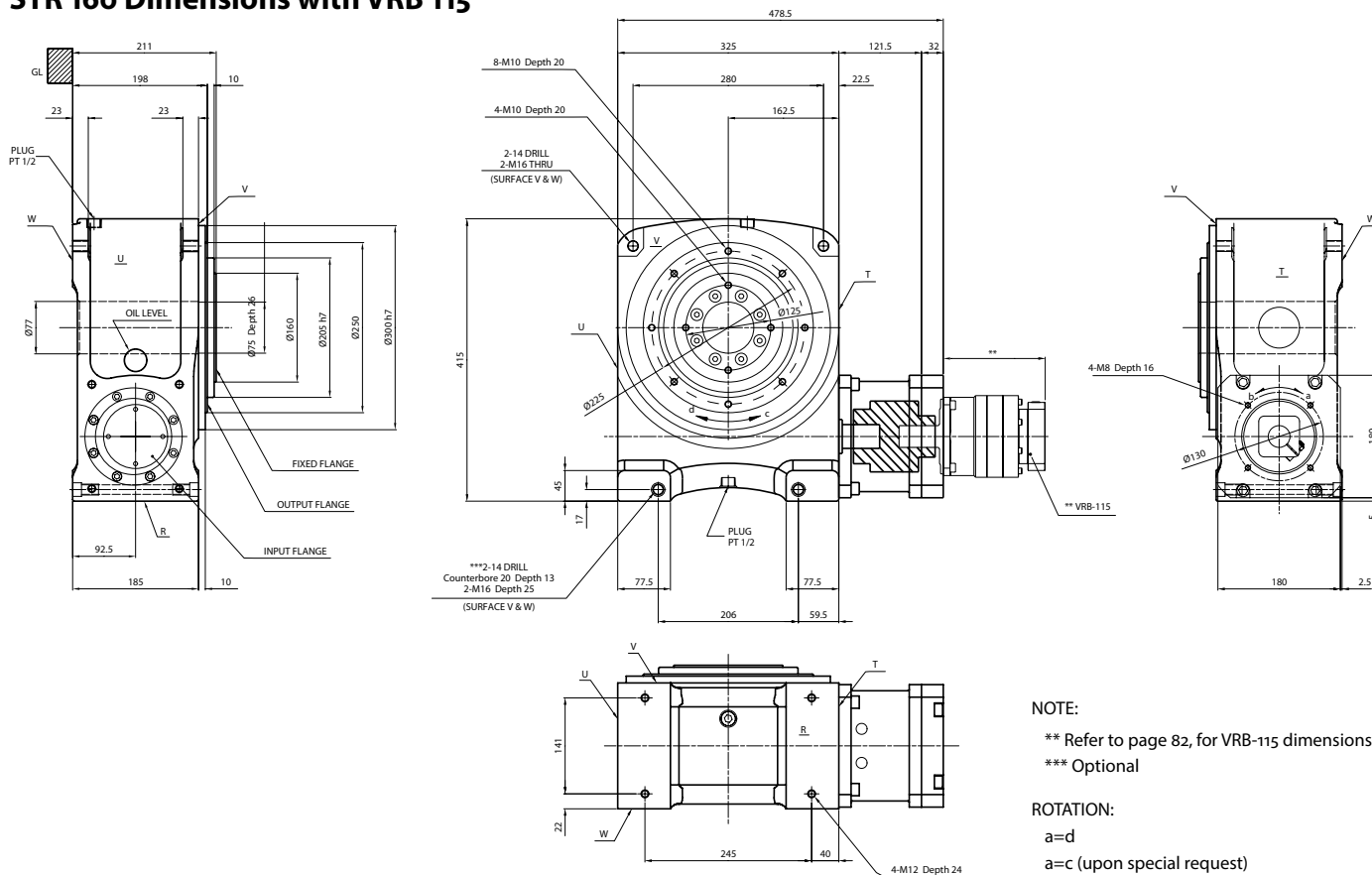

NOTE:

\*\* Refer to page 82, for VRB-115 dimensions

\*\*\* Optional

ROTATION:

a=d

a=c (upon special request)