

STR SERIES Hollow Rotary Index Tables

STR 125E 1-Stage and 2-Stage Specifications with EVB 090

Frame Size	125E									
Stage			1-Stage	2-Stage						
Ratio	Units	Notes	20	60	80	100	120	140	160	180
Nominal Torque	[Nm]	*1	548	548	548	548	548	548	548	548
Acceleration Torque	[Nm]	--	939	939	939	939	939	939	939	939
No Load Torque	[Nm]	*1	3.8	1.3	1.3	1.3	1.3	1.3	1.3	1.3
Nominal Input Speed	[rpm]	*2	600	1800	2400	3000	3000	3000	3000	3000
Maximum Input Speed	[rpm]	*2	1600	4800	6000	6000	6000	6000	6000	6000
Reflected Inertia (Single)	[kg-m ² x10 ⁻⁴]	*3	14.85	--	--	--	--	--	--	--
Reflected Inertia (≤Ø 8)	[kg-m ² x10 ⁻⁴]	*3	--	--	--	--	--	--	--	--
Reflected Inertia (≤Ø 14)	[kg-m ² x10 ⁻⁴]	*3	--	2.147	1.927	1.837	1.797	1.767	1.747	1.737
Reflected Inertia (≤Ø 19)	[kg-m ² x10 ⁻⁴]	*3	--	2.477	2.257	2.167	2.127	2.097	2.077	2.067
Reflected Inertia (≤Ø 28)	[kg-m ² x10 ⁻⁴]	*3	--	4.607	4.387	4.297	4.247	4.217	4.207	4.197
Backlash	[arc-min]	--	0	0	0	0	0	0	0	0
Angular Transmission Accuracy	[arc-min]	--	≤ 0.7	≤ 0.7						
Angular Repeatability Accuracy	[arc-min]	--	± 0.08	± 0.08						
Surface Runout	[µm (max)]	--	10	10	10	10	10	10	10	10
Weight	[kg]	--	36.3	41.4	41.4	41.4	41.4	41.4	41.4	41.4
Maximum Axial Load	[N]	--	8178	8178	8178	8178	8178	8178	8178	8178
Maximum Radial Load	[N]	--	7452	7452	7452	7452	7452	7452	7452	7452
Maximum Tilting Moment Load	[Nm]	--	764	764	764	764	764	764	764	764
Efficiency	[%]	--	80	72	72	72	72	72	72	72
Protection Class	--	*4	IP54 (IP65)							

*1) At nominal input speed

*2) Speeds are at the actuator input. Limits when used with additional gearbox are higher

*3) At input shaft

*4) IP65 (wash-down) is available as an option. Contact NIDEC-SHIMPO for more details and our food grade options

STR 125E 2-Stage and 3-Stage Specifications with EVB 090

Frame Size	125E									
Stage			2-Stage	3-Stage						
Ratio	Units	Notes	200	300	320	400	500	560	600	700
Nominal Torque	[Nm]	*1	548	548	548	548	548	548	548	548
Acceleration Torque	[Nm]	--	939	939	939	939	939	939	939	939
No Load Torque	[Nm]	*1	1.3	0.7	0.7	0.7	0.7	0.7	0.7	0.7
Nominal Input Speed	[rpm]	*2	3000	3000	3000	3000	3000	3000	3000	3000
Maximum Input Speed	[rpm]	*2	6000	6000	6000	6000	6000	6000	6000	6000
Reflected Inertia (Single)	[kg-m ² x10 ⁻⁴]	*3	--	--	--	--	--	--	--	--
Reflected Inertia (≤Ø 8)	[kg-m ² x10 ⁻⁴]	*3	--	0.377	0.417	0.367	0.357	0.407	0.287	0.357
Reflected Inertia (≤Ø 14)	[kg-m ² x10 ⁻⁴]	*3	1.727	0.447	0.497	0.437	0.437	0.487	0.367	0.437
Reflected Inertia (≤Ø 19)	[kg-m ² x10 ⁻⁴]	*3	2.057	0.637	0.687	0.627	0.627	0.677	0.547	0.627
Reflected Inertia (≤Ø 28)	[kg-m ² x10 ⁻⁴]	*3	4.187	--	--	--	--	--	--	--
Backlash	[arc-min]	--	0	0	0	0	0	0	0	0
Angular Transmission Accuracy	[arc-min]	--	≤ 0.7	≤ 0.7						
Angular Repeatability Accuracy	[arc-min]	--	± 0.08	± 0.08						
Surface Runout	[µm (max)]	--	10	10	10	10	10	10	10	10
Weight	[kg]	--	41.4	40.7	40.7	40.7	40.7	40.7	40.7	40.7
Maximum Axial Load	[N]	--	8178	8178	8178	8178	8178	8178	8178	8178
Maximum Radial Load	[N]	--	7452	7452	7452	7452	7452	7452	7452	7452
Maximum Tilting Moment Load	[Nm]	--	764	764	764	764	764	764	764	764
Efficiency	[%]	--	72	68	68	68	68	68	68	68
Protection Class	--	*4	IP54 (IP65)							

*1) At nominal input speed

*2) Speeds are at the actuator input. Limits when used with additional gearbox are higher

*3) At input shaft

*4) IP65 (wash-down) is available as an option. Contact NIDEC-SHIMPO for more details and our food grade options

STR 125E 3-Stage Specifications with EVB 090

Frame Size	125E									
Stage	3-Stage									
Ratio	Units	Notes	800	900	1000	1200	1400	1600	1800	2000
Nominal Torque	[Nm]	*1	548	548	548	548	548	548	548	548
Acceleration Torque	[Nm]	--	939	939	939	939	939	939	939	939
No Load Torque	[Nm]	*1	0.7	0.7	0.7	0.7	0.7	0.7	0.7	0.7
Nominal Input Speed	[rpm]	*2	3000	3000	3000	3000	3000	3000	3000	3000
Maximum Input Speed	[rpm]	*2	6000	6000	6000	6000	6000	6000	6000	6000
Reflected Inertia (Single)	[kg·m ² ×10 ⁻⁴]	*3	--	--	--	--	--	--	--	--
Reflected Inertia (≤Ø 8)	[kg·m ² ×10 ⁻⁴]	*3	0.287	0.357	0.287	0.287	0.287	0.287	0.287	0.287
Reflected Inertia (≤Ø 14)	[kg·m ² ×10 ⁻⁴]	*3	0.357	0.427	0.357	0.357	0.357	0.357	0.357	0.357
Reflected Inertia (≤Ø 19)	[kg·m ² ×10 ⁻⁴]	*3	0.547	0.617	0.547	0.547	0.547	0.547	0.547	0.547
Reflected Inertia (≤Ø 28)	[kg·m ² ×10 ⁻⁴]	*3	--	--	--	--	--	--	--	--
Backlash	[arc-min]	--	0	0	0	0	0	0	0	0
Angular Transmission Accuracy	[arc-min]	--	≤ 0.7							
Angular Repeatability Accuracy	[arc-min]	--	± 0.08							
Surface Runout	[µm (max)]	--	10	10	10	10	10	10	10	10
Weight	[kg]	--	40.7	40.7	40.7	40.7	40.7	40.7	40.7	40.7
Maximum Axial Load	[N]	--	8178	8178	8178	8178	8178	8178	8178	8178
Maximum Radial Load	[N]	--	7452	7452	7452	7452	7452	7452	7452	7452
Maximum Tilting Moment Load	[Nm]	--	764	764	764	764	764	764	764	764
Efficiency	[%]	--	68	68	68	68	68	68	68	68
Protection Class	--	*4	IP54 (IP65)							

*1) At nominal input speed

*2) Speeds are at the actuator input. Limits when used with additional gearbox are higher

*3) At input shaft

*4) IP65 (wash-down) is available as an option. Contact NIDEC-SHIMPO for more details and our food grade options

STR 125 Dimensions with EVB 090

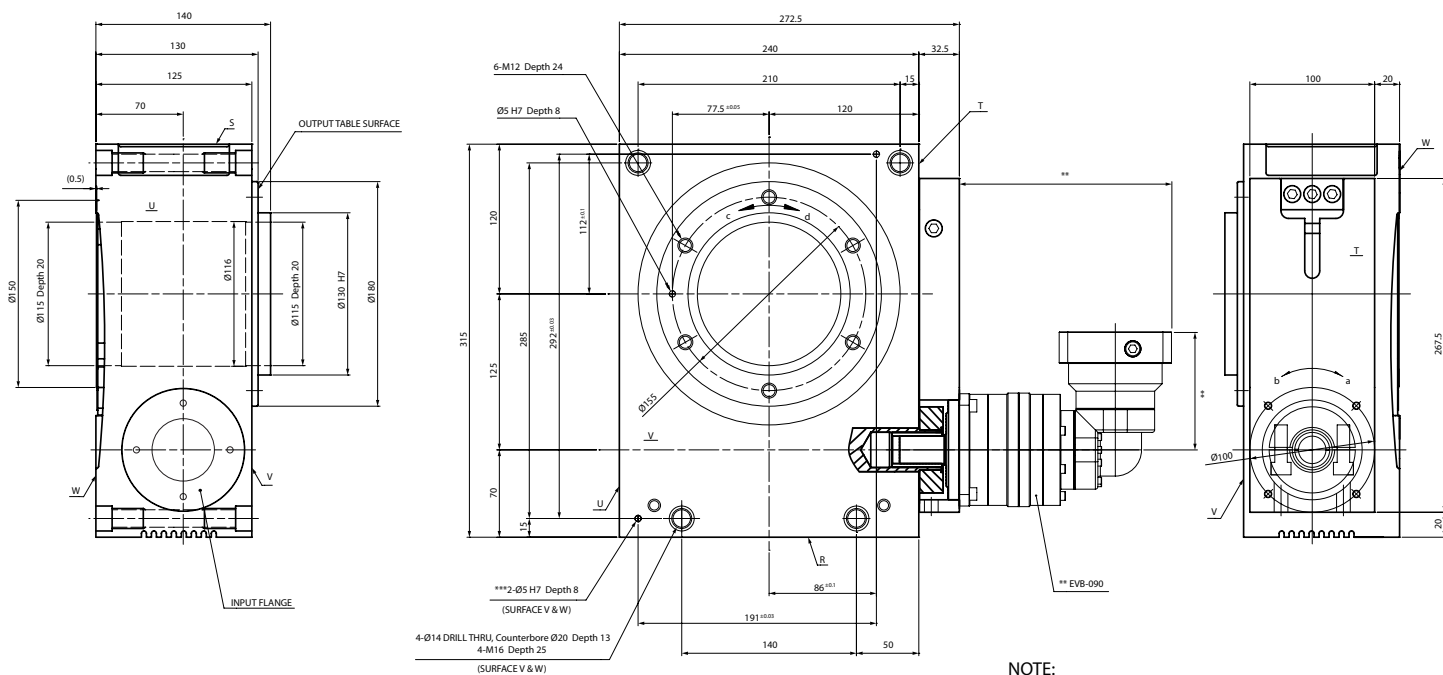

NOTE:

** Refer to page 222, for EVB-090 dimensions

*** Optional

ROTATION:

a=d

a=c (upon special request)