

# STR SERIES Hollow Rotary Index Tables

## STR o8oV 1-Stage and 2-Stage Specifications with VRB o6o

Frame Size	080V									
Stage			1-Stage	2-Stage						
Ratio	Units	Notes	20	60	80	100	120	140	160	180
Nominal Torque	[Nm]	*1	113	113	113	113	113	113	113	113
Acceleration Torque	[Nm]	--	202	202	202	202	202	202	202	202
No Load Torque	[Nm]	*1	1.3	0.1	0.1	0.1	0.1	0.1	0.1	0.1
Nominal Input Speed	[rpm]	*2	700	2100	2800	3000	3000	3000	3000	3000
Maximum Input Speed	[rpm]	*2	2500	6000	6000	6000	6000	6000	6000	6000
Reflected Inertia (Single)	[kg-m <sup>2</sup> x10 <sup>-4</sup> ]	*3	3.066	--	--	--	--	--	--	--
Reflected Inertia (≤Ø 8)	[kg-m <sup>2</sup> x10 <sup>-4</sup> ]	*3	--	0.148	0.103	0.085	0.076	0.070	0.067	0.065
Reflected Inertia (≤Ø 14)	[kg-m <sup>2</sup> x10 <sup>-4</sup> ]	*3	--	0.228	0.178	0.168	0.158	0.148	0.148	0.148
Reflected Inertia (≤Ø 19)	[kg-m <sup>2</sup> x10 <sup>-4</sup> ]	*3	--	0.438	0.388	0.368	0.368	0.358	0.358	0.348
Backlash	[arc-min]	--	0	0	0	0	0	0	0	0
Angular Transmission Accuracy	[arc-min]	--	≤ 0.7	≤ 0.7						
Angular Repeatability Accuracy	[arc-min]	--	± 0.08	± 0.08						
Surface Runout	[µm (max)]	--	10	10	10	10	10	10	10	10
Weight	[kg]	--	11.6	13.0	13.0	13.0	13.0	13.0	13.0	13.0
Maximum Axial Load	[N]	--	3302	3302	3302	3302	3302	3302	3302	3302
Maximum Radial Load	[N]	--	2819	2819	2819	2819	2819	2819	2819	2819
Maximum Tilting Moment Load	[Nm]	--	210	210	210	210	210	210	210	210
Efficiency	[%]	--	80	76	76	76	76	76	76	76
Protection Class	--	*4	IP54 (IP65)							

\*1) At nominal input speed

\*2) Speeds are at the actuator input. Limits when used with additional gearbox are higher

\*3) At input shaft

\*4) IP65 (wash-down) is available as an option. Contact NIDEC-SHIMPO for more details and our food grade options

## STR o8oV 2-Stage and 3-Stage Specifications with VRB o6o

Frame Size	080V									
Stage			2-Stage	3-Stage						
Ratio	Units	Notes	200	300	320	400	500	560	600	700
Nominal Torque	[Nm]	*1	113	113	113	113	113	113	113	113
Acceleration Torque	[Nm]	--	202	202	202	202	202	202	202	202
No Load Torque	[Nm]	*1	0.1	0.1	0.1	0.1	0.1	0.1	0.1	0.1
Nominal Input Speed	[rpm]	*2	3000	3000	3000	3000	3000	3000	3000	3000
Maximum Input Speed	[rpm]	*2	6000	6000	6000	6000	6000	6000	6000	6000
Reflected Inertia (Single)	[kg-m <sup>2</sup> x10 <sup>-4</sup> ]	*3	--	--	--	--	--	--	--	--
Reflected Inertia (≤Ø 8)	[kg-m <sup>2</sup> x10 <sup>-4</sup> ]	*3	0.064	0.063	0.065	0.062	0.061	0.063	0.057	0.061
Reflected Inertia (≤Ø 14)	[kg-m <sup>2</sup> x10 <sup>-4</sup> ]	*3	0.148	0.148	0.148	0.138	0.138	0.148	0.138	0.138
Reflected Inertia (≤Ø 19)	[kg-m <sup>2</sup> x10 <sup>-4</sup> ]	*3	0.348	0.358	0.368	0.358	0.358	0.368	0.348	0.358
Backlash	[arc-min]	--	0	0	0	0	0	0	0	0
Angular Transmission Accuracy	[arc-min]	--	≤ 0.7	≤ 0.7						
Angular Repeatability Accuracy	[arc-min]	--	± 0.08	± 0.08						
Surface Runout	[µm (max)]	--	10	10	10	10	10	10	10	10
Weight	[kg]	--	13.0	13.2	13.2	13.2	13.2	13.2	13.2	13.2
Maximum Axial Load	[N]	--	3302	3302	3302	3302	3302	3302	3302	3302
Maximum Radial Load	[N]	--	2819	2819	2819	2819	2819	2819	2819	2819
Maximum Tilting Moment Load	[Nm]	--	210	210	210	210	210	210	210	210
Efficiency	[%]	--	76	72	72	72	72	72	72	72
Protection Class	--	*4	IP54 (IP65)							

\*1) At nominal input speed

\*2) Speeds are at the actuator input. Limits when used with additional gearbox are higher

\*3) At input shaft

\*4) IP65 (wash-down) is available as an option. Contact NIDEC-SHIMPO for more details and our food grade options

## STR o80V 3-Stage Specifications with VRB o60

Frame Size	080V									
	3-Stage									
Stage	Units	Notes	800	900	1000	1200	1400	1600	1800	2000
Ratio	[Nm]	*1	113	113	113	113	113	113	113	113
Nominal Torque	[Nm]	--	202	202	202	202	202	202	202	202
Acceleration Torque	[Nm]	*1	0.1	0.1	0.1	0.1	0.1	0.1	0.1	0.1
No Load Torque	[rpm]	*2	3000	3000	3000	3000	3000	3000	3000	3000
Nominal Input Speed	[rpm]	*2	6000	6000	6000	6000	6000	6000	6000	6000
Maximum Input Speed	[kg·m <sup>2</sup> ×10 <sup>-4</sup> ]	*3	--	--	--	--	--	--	--	--
Reflected Inertia (Single)	[kg·m <sup>2</sup> ×10 <sup>-4</sup> ]	*3	0.057	0.061	0.057	0.057	0.057	0.057	0.057	0.057
Reflected Inertia (≤Ø 8)	[kg·m <sup>2</sup> ×10 <sup>-4</sup> ]	*3	0.138	0.138	0.138	0.138	0.138	0.138	0.138	0.138
Reflected Inertia (≤Ø 14)	[kg·m <sup>2</sup> ×10 <sup>-4</sup> ]	*3	0.348	0.358	0.348	0.348	0.348	0.348	0.348	0.348
Reflected Inertia (≤Ø 19)	[arc-min]	--	0	0	0	0	0	0	0	0
Backlash	[arc-min]	--	≤ 0.7							
Angular Transmission Accuracy	[arc-min]	--	± 0.08							
Angular Repeatability Accuracy	[μm (max)]	--	10	10	10	10	10	10	10	10
Surface Runout	[kg]	--	13.2	13.2	13.2	13.2	13.2	13.2	13.2	13.2
Weight	[N]	--	3302	3302	3302	3302	3302	3302	3302	3302
Maximum Axial Load	[N]	--	2819	2819	2819	2819	2819	2819	2819	2819
Maximum Radial Load	[Nm]	--	210	210	210	210	210	210	210	210
Maximum Tilting Moment Load	[%]	--	72	72	72	72	72	72	72	72
Efficiency			IP54 (IP65)							
Protection Class										

\*1) At nominal input speed

\*2) Speeds are at the actuator input. Limits when used with additional gearbox are higher

\*3) At input shaft

\*4) IP65 (wash-down) is available as an option. Contact NIDEC-SHIMPO for more details and our food grade options

## STR o80V Dimensions with VRB o60

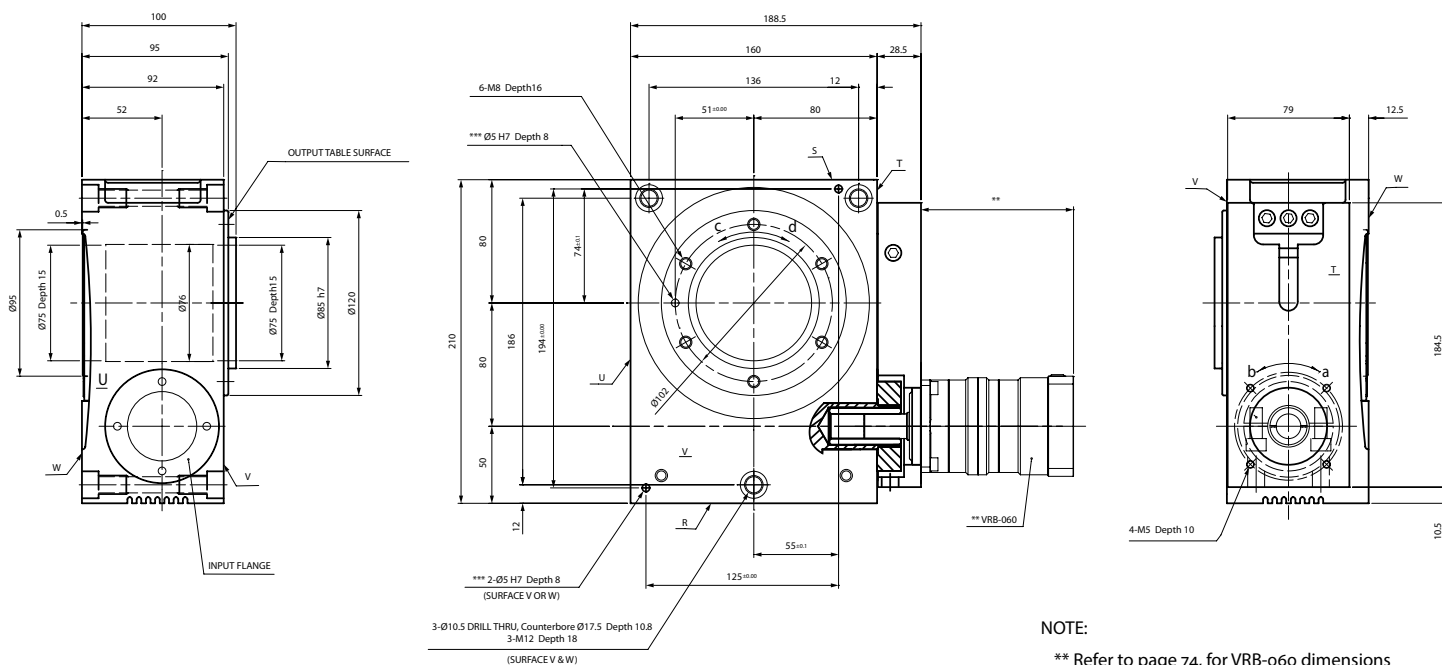

NOTE:

\*\* Refer to page 74, for VRB-o60 dimensions

\*\*\* Optional

ROTATION:

a=d

a=c (upon special request)