

EVS-SERIES Right-angle shaft

EVS-075 – 2-Stage Adapter Dimensions

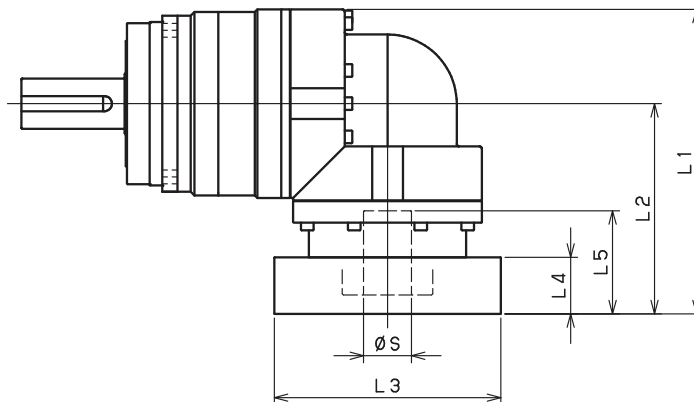

Model number	**: Adapter code	2-Stage				
		L1	L2	L3	L4	L5
EVS-075-□-□-8** (S ≤ 8)	AA·AC·AD·AF·AG·AL·AM·AN·AQ	--	--	--	--	--
	AB·AE·AH·AJ·AK	--	--	--	--	--
	BA·BB·BD·BE·BG·BH·BJ	--	--	--	--	--
	CA	--	--	--	--	--
EVS-075-□-□-14** (8 < S ≤ 14)	BA·BB·BD·BE·BF·BG·BH·BJ·BK·BP	137.5	92	□65	16.5	35
	BC·BH·BM·BN	142.5	97	□65	21.5	40
	CA·CC	137.5	92	□70	16.5	35
	DA·DB·DC·DD·DF·DH·DJ	137.5	92	□80	16.5	35
	EA·EB·EC·EF·EG·EK·EL	137.5	92	□90	16.5	35
	FA	137.5	92	□100	16.5	35
	FB	147.5	102	□100	26.5	45
EVS-075-□-□-19** (14 < S ≤ 19)	DA·DB·DC	145.5	100	□80	25	50
	EB·ED	145.5	100	□90	25	50
	FA	145.5	100	□100	25	50
	FB	155.5	110	□100	35	60
	GA·GC·GH	150.5	105	□115	30	55
	GB·GD·GJ	145.5	100	□115	25	50
	GE·GF	155.5	110	□115	35	60
	HA	145.5	100	□130	25	50
	HB	160.5	115	□130	40	65
	HC·HD·HE	150.5	105	□130	30	55
	JA	155.5	110	□150	35	60
EVS-075-□-□-28** (19 < S ≤ 28)	JB	160.5	115	□150	40	65
	FA·FB·FC	174.5	129	□100	35	67
	FD·FE	169.5	124	□100	30	62
	GA·GB·GC·GD·GE·GF·GG·GH	174.5	129	□115	35	67
	HA·HC·HD	174.5	129	□130	35	67
	HB	184.5	139	□130	45	77
	HE	189.5	144	□130	50	82
	HF	169.5	124	□130	30	62
	JA·JB·JC·JF	174.5	129	□150	35	67
JD	194.5	149	□150	55	87	
JE	184.5	139	□150	45	77	

*1) Double reduction : 1/3~ 1/10

*2) Bushing will be inserted to adapt to motor shaft

For an explanation on the Adapter Flange Code, please turn to page 422.

A more comprehensive adapter flange offering can be found using the NIDEC-SHIMPO Online Selector Tool. The variety is constantly expanding and being updated on the Selector Tool. If you have any questions or need any support, contact NIDEC-SHIMPO.

EVS-075 – 3-Stage Adapter Dimensions

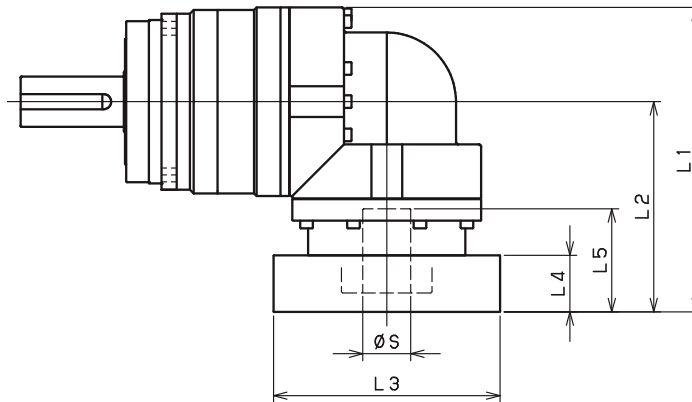

Model number	**: Adapter code	3-Stage				
		L1	L2	L3	L4	L5
EVS-075-□-□-8** (S ≤ 8)	AA·AC·AD·AF·AG·AL·AM·AN·AQ	116	71.5	□52	15.5	32
	AB·AE·AH·AJ·AK	121	76.5	□52	20.5	37
	BA·BB·BD·BE·BG·BH·BJ	116	71.5	□60	15.5	32
	CA	121	76.5	□70	20.5	37
EVS-075-□-□-14** (8 < S ≤ 14)	BA·BB·BD·BE·BF·BG·BH·BJ·BK·BP	122	77.5	□65	16.5	35
	BC·BH·BM·BN	127	82.5	□65	21.5	40
	CA·CC	122	77.5	□70	16.5	35
	DA·DB·DC·DD·DF·DH·DJ	122	77.5	□80	16.5	35
	EA·EB·EC·EF·EG·EK·EL	122	77.5	□90	16.5	35
	FA	122	77.5	□100	16.5	35
	FB	132	87.5	□100	26.5	45
EVS-075-□-□-19** (14 < S ≤ 19)	DA·DB·DC	139	94.5	□80	25	50
	EB·ED	139	94.5	□90	25	50
	FA	139	94.5	□100	25	50
	FB	149	104.5	□100	35	60
	GA·GC·GH	144	99.5	□115	30	55
	GB·GD·GJ	139	94.5	□115	25	50
	GE·GF	149	104.5	□115	35	60
	HA	139	94.5	□130	25	50
	HB	154	109.5	□130	40	65
	HC·HD·HE	144	99.5	□130	30	55
	JA	149	104.5	□150	35	60
EVS-075-□-□-28** (19 < S ≤ 28)	FA·FB·FC	--	--	--	--	--
	FD·FE	--	--	--	--	--
	GA·GB·GC·GD·GE·GF·GG·GH	--	--	--	--	--
	HA·HC·HD	--	--	--	--	--
	HB	--	--	--	--	--
	HE	--	--	--	--	--
	HF	--	--	--	--	--
	JA·JB·JC·JF	--	--	--	--	--
	JD	--	--	--	--	--
JE	--	--	--	--	--	

*1) Triple reduction : 1/15~ 1/100

*2) Bushing will be inserted to adapt to motor shaft

For an explanation on the Adapter Flange Code, please turn to page 422.

A more comprehensive adapter flange offering can be found using the NIDEC-SHIMPO Online Selector Tool. The variety is constantly expanding and being updated on the Selector Tool. If you have any questions or need any support, contact NIDEC-SHIMPO.