

# EVL-SERIES Right-angle shaft

## EVL-205 – 2-Stage Adapter Dimensions

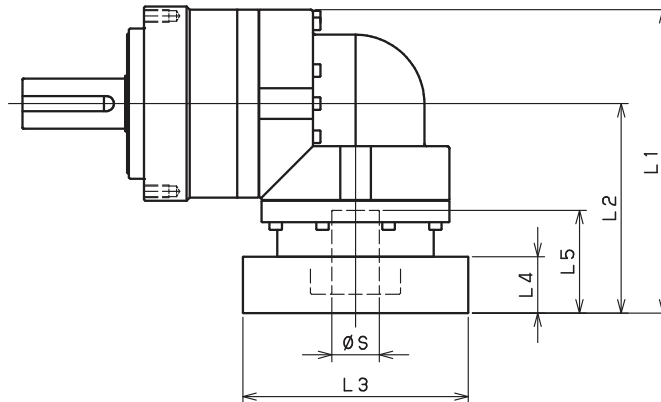

Model number	**: Adapter code	2-Stage				
		L1	L2	L3	L4	L5
EVL-205-□-□-28** (S ≤ 28)	FA•FB•FC	--	--	--	--	--
	GA•GB•GC•GD•GE•GF•GG•GH	--	--	--	--	--
	HA•HC•HD	--	--	--	--	--
	HB	--	--	--	--	--
	HF	--	--	--	--	--
	JA•JB•JC•JF	--	--	--	--	--
	KA•KB•KE	--	--	--	--	--
	LA	--	--	--	--	--
	LB	--	--	--	--	--
	MA	--	--	--	--	--
EVL-205-□-□-38** (28 < S ≤ 38)	HA	331.5	231.5	□130	45	82
	HB•HE	326.5	226.5	□130	40	77
	JA	331.5	231.5	□150	45	82
	KA•KB•KC	331.5	231.5	□180	45	82
	KD	366.5	266.5	□180	80	117
	KE	346.5	246.5	□180	60	97
	LA	331.5	231.5	□200	45	82
	LB	341.5	241.5	□200	55	92
	MA•MB	331.5	231.5	□220	45	82
	MC	346.5	246.5	□220	60	97
	MD	341.5	241.5	□220	55	92
EVL-205-□-□-48** (38 < S ≤ 48)	KA	368	268	□180	75	118
	KB•KC	348	248	□180	55	98
	LA	348	248	□200	55	98
	MA	348	248	□220	55	98
	MB	368	268	□220	75	118
	NA	368	268	□250	75	118
	PA	368	268	□280	75	118
EVL-205-□-□-65** (48 < S ≤ 65)	MA•MB•MC•MD	381	281	□220	80	122
	NA•NC	381	281	□250	80	122
	NB•ND	411	311	□250	110	152
	PA	401	301	□280	100	142
	PB	411	311	□280	110	152

\*1) Double reduction : 1/3~ 1/10

\*2) Bushing will be inserted to adapt to motor shaft

For an explanation on the Adapter Flange Code, please turn to page 422.

A more comprehensive adapter flange offering can be found using the NIDEC-SHIMPO Online Selector Tool. The variety is constantly expanding and being updated on the Selector Tool. If you have any questions or need any support, contact NIDEC-SHIMPO.

## EVL-205 – 3-Stage Adapter Dimensions

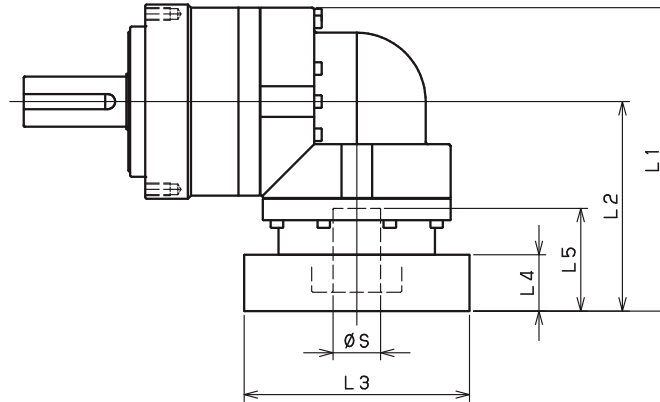

Model number	**: Adapter code	3-Stage				
		L1	L2	L3	L4	L5
EVL-205-□-□-28** (S ≤ 28)	FA•FB•FC	252	152	□100	35	67
	GA•GB•GC•GD•GE•GF•GG•GH	252	152	□115	35	67
	HA•HC•HD	252	152	□130	35	67
	HB	262	162	□130	45	77
	HF	247	147	□130	30	62
	JA•JB•JC•JF	252	152	□150	35	67
	KA•KB•KE	252	152	□180	35	67
	LA	252	152	□200	35	67
	LB	262	162	□200	45	77
	MA	252	152	□220	35	67
	MB	262	162	□220	45	77
EVL-205-□-□-38** (28 < S ≤ 38)	HA	267	167	□130	45	82
	HB•HE	262	162	□130	40	77
	JA	267	167	□150	45	82
	KA•KB•KC	267	167	□180	45	82
	KD	302	202	□180	80	117
	KE	282	182	□180	60	97
	LA	267	167	□200	45	82
	LB	277	177	□200	55	92
	MA•MB	267	167	□220	45	82
	MC	282	182	□220	60	97
	MD	277	177	□220	55	92
EVL-205-□-□-48** (38 < S ≤ 48)	KA	313	213	□180	75	118
	KB•KC	293	193	□180	55	98
	LA	293	193	□200	55	98
	MA	293	193	□220	55	98
	MB	313	213	□220	75	118
	NA	313	213	□250	75	118
	PA	313	213	□280	75	118
EVL-205-□-□-65** (48 < S ≤ 65)	MA•MB•MC•MD	--	--	--	--	--
	NA•NC	--	--	--	--	--
	NB•ND	--	--	--	--	--
	PA	--	--	--	--	--
	PB	--	--	--	--	--

\*1) Triple reduction : 1/15~ 1/100

\*2) Bushing will be inserted to adapt to motor shaft

For an explanation on the Adapter Flange Code, please turn to page 422.

A more comprehensive adapter flange offering can be found using the NIDEC-SHIMPO Online Selector Tool. The variety is constantly expanding and being updated on the Selector Tool. If you have any questions or need any support, contact NIDEC-SHIMPO.